

**NATIONAL SAFETY CODE
Standard 10 – Cargo Securement**

Guidance:

**Securement of
Dressed Lumber and Similar Building Materials
on Flatbed Trucks and Trailers**

June 18, 2006

Disclaimer

The guidance that is provided in this document is offered for convenience only. For accurate reference, please consult the National Safety Code Standard 10 (www.ccmta.ca) and the applicable provincial and territorial regulations.

***Minimum Strength of Securement System (DIVISION 3, Section 10)**

- The **aggregate working load limit** of the cargo securement system used to secure an article or group of articles of cargo on or within a vehicle shall be not less than 50% of the weight of the article or total weight of the group.
- “**Aggregate working load limit**” is the sum of One-half of the working load limit for each end section of a tiedown that is attached to an anchor point.

Section

41(1) Application

This division applies to the transportation of **bundles** of dressed lumber and packaged lumber, and unitized building products, including plywood, gypsum board or other materials of similar shape.

42 Side by Side

Where bundles are placed **side by side** each bundle shall be in direct contact with each other, or a method shall be used that prevents the bundles from moving towards each other.

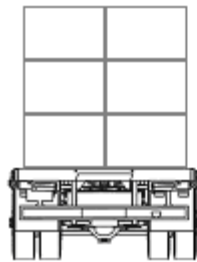

CORRECT

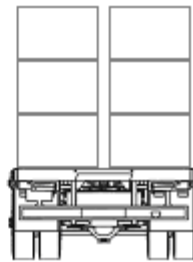

INCORRECT

46(1) Bundles placed directly on top of other bundles

Bundles carried in 2 or more layers placed directly on top of other bundles, or on spacers of adequate size and orientation, shall be secured by

- Tiedowns over the top layer of bundles, in accordance with provisions of section 22 of this Standard, with a minimum of two tiedowns for bundle(s) longer than 1.52 m (5'), and
- Tiedowns over the second layer of bundles, or at 1.85m (6') above the vehicle deck, whichever is greater, or not over 1.85 m (6') above the deck for other multiple layers in accordance with the provisions of section 22 of this Standard, for each stack of bundles composed of more than two layer

MINIMUM NUMBER OF TIEDOWNS REQUIRED FOR BUNDLES OF DRESSED LUMBER AND UNITIZED BUILDING PRODUCTS (SECTION 46)

ARTICLE DESCRIPTION	Layers in Stack	Article Blocked/Immobilized*		Article <u>Not</u> Blocked/Immobilized	
		Top Layer (# Tiedowns required)	Middle Layers (# Tiedowns required)	Top Layer (# Tiedowns required)	Middle Layers (# Tiedowns required)
1.52m (5ft) or shorter and 500kg (1100lb) or lighter	2 layers	1	Not required	1	Not required
	3 layers	1	1 over second layer	1	1 over second layer
	More than 3 layers	1	1 over middle layer at point not higher than 1.85m (6') above deck	1	1 over middle layer at point not higher than 1.85m (6') above deck
1.52m (5 ft) or shorter and over 500kg (1100 lb)	2 layers	1	Not required	2	Not required
	3 layers	1	1 over second layer	2	2 over second layer
	More than 3 layers	1	1 over middle layer at point not higher than 1.85m (6') above deck	2	2 over middle layer at point not higher than 1.85m (6') above deck
More than 1.52m (5 ft) but 3.04m (10 ft) or less	2 layers	2	Not required	2	Not required
	3 layers	2	1 over second layer	2	2 over second layer
	More than 3 layers	2	1 over middle layer at point not higher than 1.85m (6') above deck	2	2 over middle layer at point not higher than 1.85m (6') above deck
Longer than 3.04m (10 ft)	2 layers	<ul style="list-style-type: none"> • 1 tiedown for first 3.04m (10') of cargo, plus • 1 tiedown for every 3.04m (10') or part thereof 	Not required	<ul style="list-style-type: none"> • 2 tiedowns for first 3.04m (10') of cargo, plus • 1 tiedown for every 3.04m (10') or part thereof 	Not required
	3 layers	<ul style="list-style-type: none"> • 1 tiedown for first 3.04m (10') of cargo, plus • 1 tiedown for every 3.04m (10') or part thereof 	Tiedowns over second layer: <ul style="list-style-type: none"> • 1 for first 3.04m (10') of cargo, plus • 1 tiedown for every 3.04m (10') or part thereof 	<ul style="list-style-type: none"> • 2 tiedowns for first 3.04m (10') of cargo, plus • 1 tiedown for every 3.04m (10') or part thereof 	Tiedowns over second layer: <ul style="list-style-type: none"> • 2 for first 3.04m (10') of cargo, plus • 1 tiedown for every 3.04m (10') or part thereof
	More than 3 layers	<ul style="list-style-type: none"> • 1 tiedown for first 3.04m (10') of cargo, plus • 1 tiedown for every 3.04m (10') or part thereof 	Tiedowns over middle layer at point not higher than 1.85m (6') above deck: <ul style="list-style-type: none"> • 1 for first 3.04m (10') of cargo, plus • 1 tiedown for every 3.04m (10') or part thereof 	<ul style="list-style-type: none"> • 2 tiedowns for first 3.04m (10') of cargo, plus • 1 tiedown for every 3.04m (10') or part thereof 	Tiedowns over middle layer at point not higher than 1.85m (6') above deck: <ul style="list-style-type: none"> • 2 for first 3.04m (10') of cargo, plus • 1 tiedown for every 3.04m (10') or part thereof

*Articles of cargo must be blocked or immobilized by a front-end structure, bulkhead or other immobilized cargo to prevent it from moving forward.

Note: Additional tiedowns may be required to ensure the aggregate working load limit is at least 50% of the weight of the cargo the tiedowns are securing.

Securement Illustrations

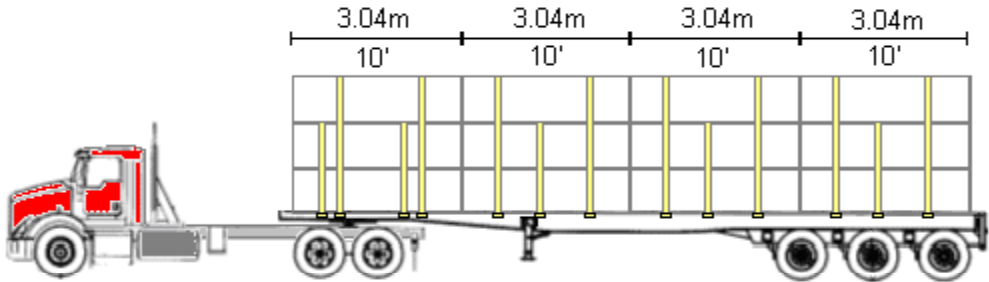

- Three layers high. First lift not butted or immobilized against vehicle structure, require at least 2 belly wrap tiedowns. Second, third and fourth lifts are butted or immobilized against other bundles, therefore a minimum of 1 belly wrap tiedown required for the second, third and fourth lifts. Minimum 2 tiedowns over bundles on top layer.

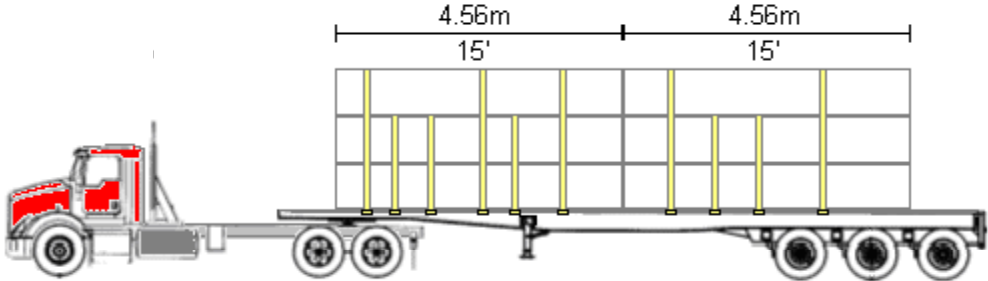

- Three layers high. First lift not butted or immobilized against vehicle structure, require at least 3 belly wrap tiedowns and a minimum of 3 tiedowns over top layer. Second lift is butted or immobilized against other bundles therefore 1 tiedown may be reduced on belly wrapped layers and top layer(s) of second lift.

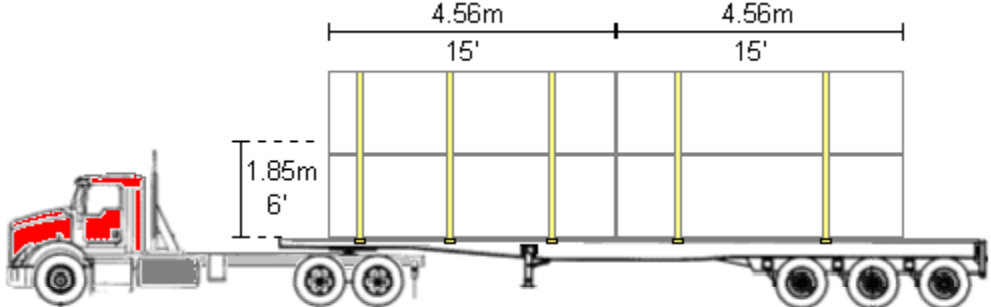

- Only two layers high, therefore does not require belly wrap tiedowns. Must meet the 50% aggregate WLL for tiedowns over top layers.

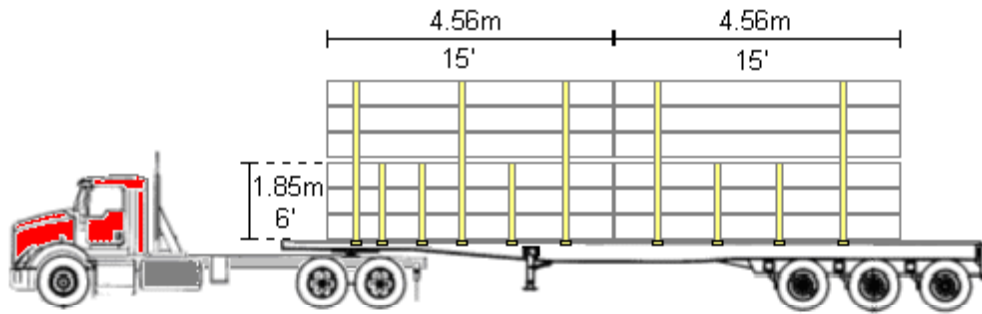

- More than three layers high, belly wraps are required over the second or third layers, not more than 1.85m (6') from the deck.

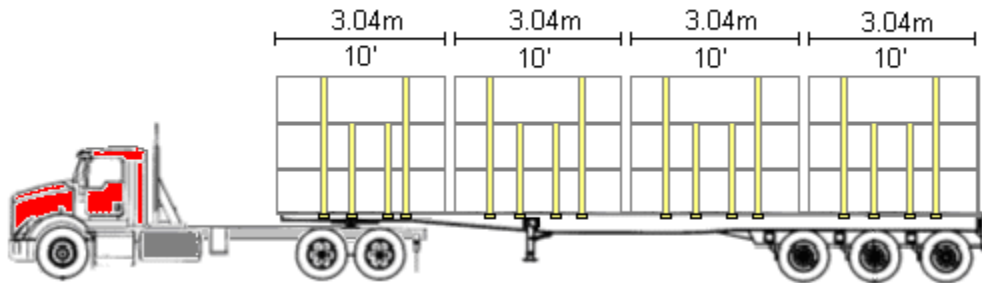

- Three layers high, four lifts not butted or immobilized against forward movement therefore requires a minimum of two belly wrap tiedowns over second layers and a minimum of 2 tiedowns over top layers for each group or lift due to length of cargo.

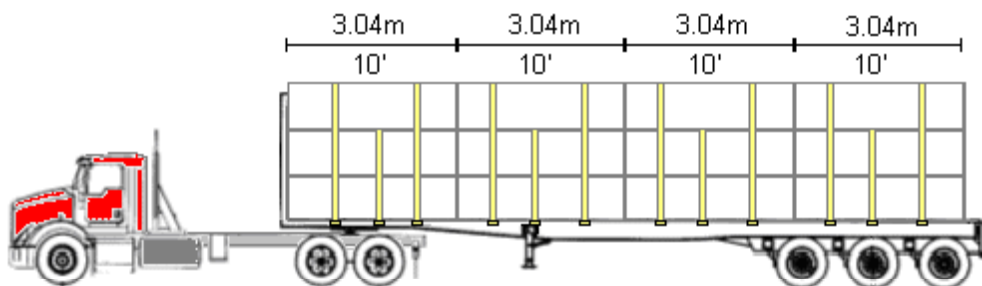

- Trailer equipped with bulkhead. Three layers high, first lift butted or immobilized against vehicle structure and each additional lift is also butted or immobilized against other bundles. Minimum 2 tiedowns on top layers. Second layers require a minimum of 1 belly wrap tiedown due to length of cargo.

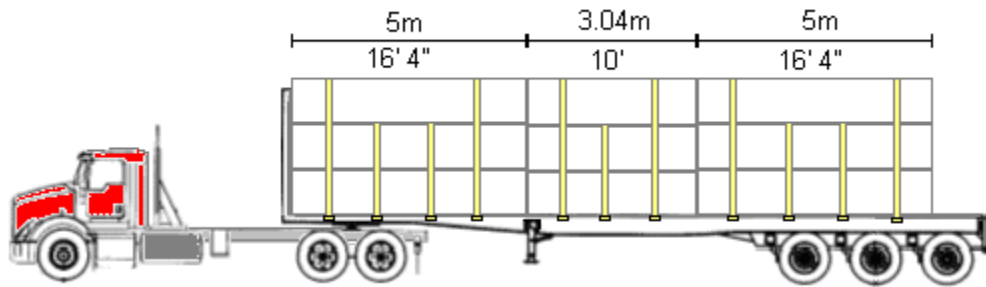

- Trailer equipped with bulkhead. Three layers high, first lift butted or immobilized against vehicle structure and each additional lift is also butted or immobilized against other bundles. Minimum 2 tiedowns required over top layers due to length of bundles. Second layers require a minimum of 2 belly wrap tiedowns for the front and rear lifts and minimum a minimum of 1 belly wrap tiedown for the middle lift, due to length of bundle.

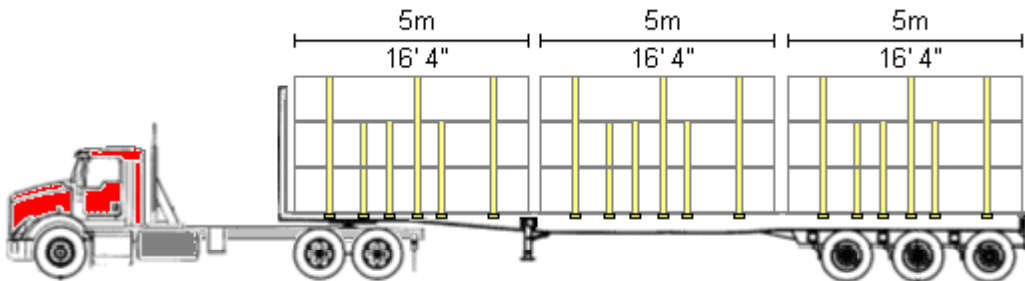

- Three layers high, three lifts not butted or immobilized against forward movement, require a minimum of 3 belly wrap tiedowns and a minimum of 3 tiedowns over top layers for each group or lift(s) due to length of bundle.

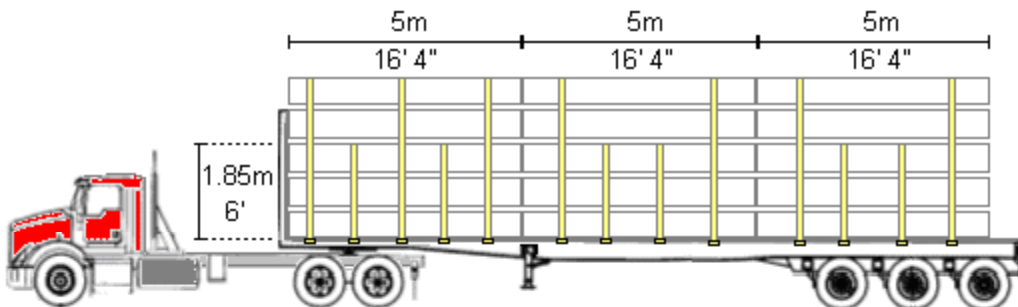

- Fifth layer on first lift not butted or immobilized against vehicle structure, therefore at least 3 tiedowns are required due to length of bundle.
- A minimum of 2 belly wrap tiedowns are required over the second or third layers on each lift (at 1.85m (6') from deck), as they are immobilized against forward movement.